

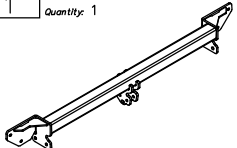



















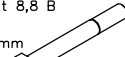

### Towbar accessories:

Pos. 1 Name: Main bar Quantity: 1 	Pos. 6 Name: Square washer Quantity: 1 Dim.: 48x48x10mm 	Pos. 12 Name: Bolt 8,8 B Quantity: 1 Dim.: M12x40mm 	Pos. 18 Name: Plain washer ø10,5mm SZTUK: 8 
	Pos. 7 Name: Square washer Quantity: 1 Dim.: 48x48x8mm 	Pos. 13 Name: Bolt 8,8 B Quantity: 4 Dim.: M12x35mm 	Pos. 19 Name: Spring washer Quantity: 10 Dim.: ø 12,2 mm 
Pos. 2 Name: Tow ball Quantity: 1 	Pos. 8 Name: Fish-plate with nut Quantity: 2 	Pos. 14 Name: Bolt 8,8 B Quantity: 4 Dim.: M10x1,25x40mm 	Pos. 20 Name: Spring washer Quantity: 6 Dim.: ø 10,2 mm 
Pos. 3 Name: Socket plate Quantity: 1 	Pos. 9 Name: Bolt 8,8 B Quantity: 2 Dim.: M12x130mm 	Pos. 15 Name: Bolt 8,8 B Quantity: 2 Dim.: M10x40mm 	Pos. 21 Name: Nut 8 B Quantity: 8 Dim.: M12 
Pos. 4 Name: Right bracket Quantity: 1 	Pos. 10 Name: Bolt 8,8 B Quantity: 2 Dim.: M12x75mm 	Pos. 16 Name: Plain washer Quantity: 2 Dim.: ø37xø13x3mm 	Pos. 22 Name: Nut 8 B Quantity: 2 Dim.: M10 
Pos. 5 Name: Left bracket Quantity: 1 	Pos. 11 Name: Bolt 8,8 B Quantity: 1 Dim.: M12x60mm 	Pos. 17 Name: Plain washer Quantity: 8 Dim.: ø 13 mm 	Pos. 23 Name: Ball's cover Quantity: 1 



**PPUH AUTO-HAK S.J.**

Produkcja Zaczepów Kulowych  
Henryk & Zbigniew Nejman  
76-200 SŁUPSK ul. Słoneczna 16K  
tel/fax (059) 8-414-414; 8-414-413  
E-mail: [office@autohak.com.pl](mailto:office@autohak.com.pl)  
[www.autohak.com.pl](http://www.autohak.com.pl)

### Towing hitch (without electrical set)

Class: A50-X Cat. no. **R39**  
**FIAT DUCATO (L1, L2, L3),**  
**PEUGEOT BOXER (L1, L2, L3),**  
**CITROEN JUMPER (L1, L2, L3)**

Type: **metal built-up**  
produced since 2006

Technical data:

**D-value: 14,3 kN**

maximum trailer weight: **2500 kg**

maximum vertical cup load: **120 kg**

Approval number according to Directive 94/20/EC: **e20\*94/20\*0192\*00**

Figure 2. Drilling only for vehicles produced since 2010:

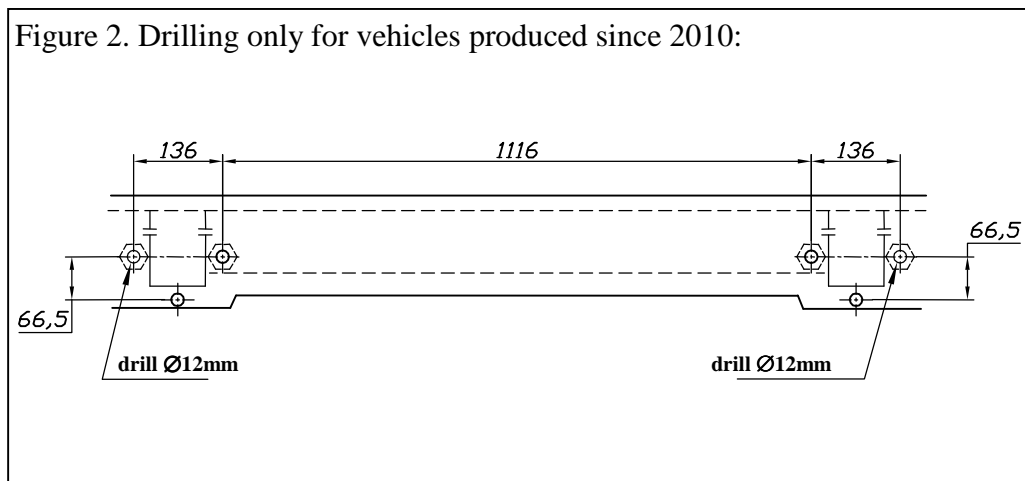

### Foreword

This towbar is designed according to rules of safety traffic regulations. The towing hitch is a safety component and can be installed only by qualified personnel. Any alteration or conversion of the towing hitch is prohibited and would lead to cancellation of design certification. Remove insulating compound and underseal from vehicle (if present) in the area of the mating surfaces of the towing hitch. The vehicle manufacturer's specifications regarding trailer load and max. vertical cup load are decisive for driving whereat values for the towing hitch cannot be exceeded.

*D-value formula:*

$$\frac{\text{Max trailer weight [kg]} \times \text{Max vehicle weight [kg]}}{\text{Max trailer weight [kg]} + \text{Max vehicle weight [kg]}} \times \frac{9,81}{1000} = D \text{ [kN]}$$

## FITTING INSTRUCTION

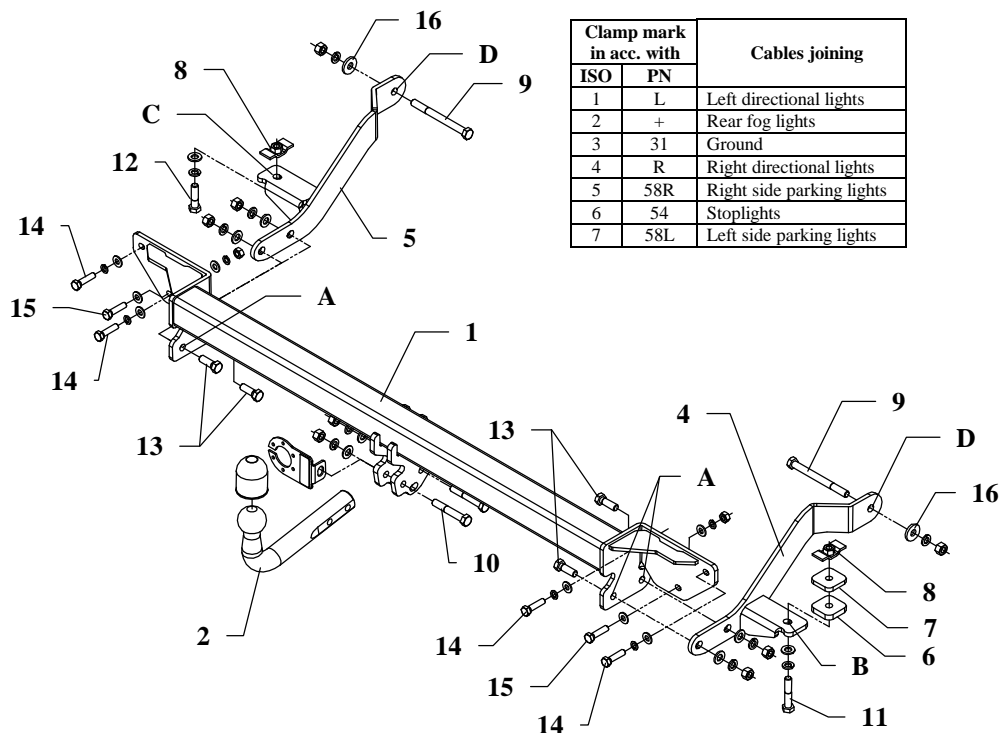

This towbar is designed to assembly in following cars: **FIAT DUCATO (L1, L2, L3), PEUGEOT BOXER (L1, L2, L3), CITROEN JUMPER (L1, L2, L3), metal built-up**, produced since 2006, catalogue no. **R39** and is prepared to tow trailers max total weight **2500 kg** and max vertical load **120 kg**.

### *From manufacturer*

Thank you for buying our product. Their reliability has been confirmed in many tests. Reliability of towbar depends also on correct assembly and right operation. For this reasons we kindly ask to read carefully this instruction and apply to hints.

*The towbar should be install in points described by a car producer.*

## The instruction of the assembly

1. Disassemble a bumper and metal reinforcement (reinforcement will not be reinstall).
2. **NOTE! Only for vehicles produced till 2010:**  
Instead of metal reinforcement fix main bar of the towbar (pos. 1) using four bolts M8 (take from disassembled reinforcement) and two bolts M10x40mm pos. 15 from towbar accessories.
- NOTE Only for vehicles produced since 2010:**  
Drill two holes  $\varnothing 12\text{mm}$  according to figure 2 (drill very carefully, do not damage thread of nuts welded inside). Instead of metal reinforcement fix main bar of the towbar (pos. 1) using four bolts M10x1,25x40mm (pos. 14) and two bolts M10x40mm (pos. 15) from towbar accessories.
3. Underneath the car find plastic square plugs in the frame. Remove them. In holes put fish-plates with nuts (pos. 8). One per each side of the chassis, see figure.
4. Fix side brackets (pos. 4 and 5) as follows:
  - through holes A by bolts M12x35mm (pos. 13)
  - through hole B by bolt M12x60mm (pos. 11) – use square washers (pos. 6 and 7)
  - through hole C by bolt M12x40mm (pos. 12)
  - through holes D by bolts M12x130mm (pos. 9)
5. Reassemble a bumper.
6. Fix tow-ball (pos. 2) with socket plate (pos. 3) using bolts M12x75mm (pos. 10) from accessories.
7. Tighten all bolts according to the torque shown in the table.
8. Connect electric wires of 7-poles socket according to the instruction of the car. (Recommend to make at authorized service station).
9. Complete paint layer damaged during installation.

Torque settings for nuts and bolts (8,8):

<b>M6</b> - 11 Nm	<b>M8</b> - 25 Nm	<b>M10</b> - 50 Nm
<b>M12</b> - 87 Nm	<b>M14</b> - 138 Nm	<b>M16</b> - 210 Nm